

HSR312, HSR312L, HSR412, HSR412L Photovoltaic Solid-State Relay Optocouplers

Features

- 4,000 VRMS Isolation
- Wide operating voltage range
- 250 V (HSR312, HSR312L)
- 400 V (HSR412, HSR412L)
- Solid-State Reliability
- Bounce-Free Operation
- 4000 V ESD Rating (HBM)
- UL and CSA approved

Applications

- On/Off Hook Switch
- Replacement for Mechanical Relays
- Dial Out Relay
- Ring Injection Relay
- General Switching
- Ground Start

Description

The HSR312 and HSR412 devices consist of a AlGaAs infrared emitting diode optically coupled to a power MOSFET detector which is driven by a photovoltaic generator. The devices are housed in a 6-pin dual-in-line package. The HSR312L and HSR412L employ an active current limit circuitry enabling the device to withstand current surge transients.

Package

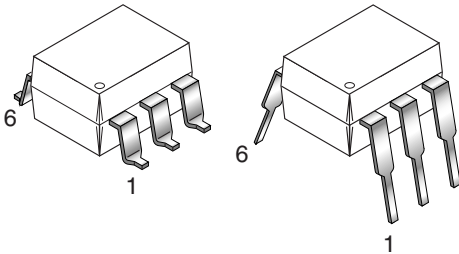

Schematic

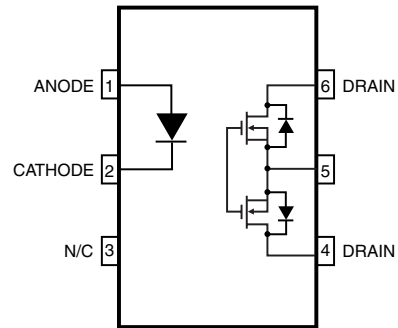

Absolute Maximum Ratings ($T_A = 25^\circ\text{C}$ unless otherwise noted)

Symbol	Parameters	Device	Value	Units
TOTAL DEVICE				
T_{STG}	Storage Temperature	All	-40 to +100	$^\circ\text{C}$
T_{OPR}	Operating Temperature	All	-40 to +85	$^\circ\text{C}$
T_{SOL}	Lead Solder Temperature	All	260 for 10 sec	$^\circ\text{C}$
V_{ISO}	Isolation Surge Voltage	All	4000	Vac(RMS)
C_{IO}	Maximum Input/Output Capacitance	All	1.0	pF
R_{IO}	Maximum Input/Output Resistance	All	10^{12}	Ω

Electrical Characteristics ($T_A = -40^\circ\text{C}$ to $+85^\circ\text{C}$ Unless otherwise specified)

Input Characteristics

Symbol	Parameters/ Test Conditions	Connection	Limit	HSR312	HSR312L	HSR412	HSR412L	Units
$I_{F(ON)}$	Control Current	Series or Parallel	Max	2.0	2.0	3.0	3.0	mA
$I_{F(OFF)}$	Control Current for Off-State Resistance	Series or Parallel	Min	0.4	0.4	0.4	0.4	mA
I_F	Control Current Range	Series or Parallel	Min	2.0	2.0	3.0	3.0	mA
			Max	25	25	25	25	
V_R	Reverse Voltage	Series or Parallel	Min	7	7	7	7	V
V_F	Forward Voltage ($I_F=10$ mA)	Series or Parallel	Max	1.6	1.6	1.6	1.6	V

Output Characteristics

Symbol	Parameters/ Test Conditions	Connection	Limit	HSR312	HSR312L	HSR412	HSR412L	Units
V_{OPR}	Operating Voltage Range	Series or Parallel	Max	250	250	400	400	V_{DC} or $V_{AC(PEAK)}$
I_L	Load Current $T_A = +40^\circ\text{C}$, 5mA control (see fig. 1 & 2)	Series	Max	190	170	140	120	mA
		Parallel	Max	320	300	210	200	
R_{ON}	On-State Resistance $T_A = 25^\circ\text{C}$, 50mA pulsed load, 5mA control	Series	Max	10	15	27	35	Ω
		Parallel	Max	3	4.25	7	9	
—	Off-State Leakage Current $T_A = 25^\circ\text{C}$, $\pm 250\text{V}$ for HSR312/L, $\pm 400\text{V}$ for HSR412/L	Series or Parallel	Max	1.0	1.0	1.0	1.0	μA
I_{LMT}	Current Limit $T_A = +25^\circ\text{C}$, 5mA control	Series	Min	N/A	190	N/A	130	mA
			Max	N/A	300	N/A	220	
		Parallel	Min	N/A	330	N/A	260	
			Max	N/A	560	N/A	440	

Output Characteristics (Continued)

Symbol	Parameters/ Test Conditions	Connection	Limit	HSR312	HSR312L	HSR412	HSR412L	Units
T_{ON}	Turn-On Time $T_A = +25^\circ\text{C}$ for 50mA, 100VDC load, 5mA control	Series or Parallel	Max	3.0	3.0	2.0	2.0	mS
T_{OFF}	Turn-Off Time $T_A = +25^\circ\text{C}$ for 50mA, 100VDC load, 5mA control	Series or Parallel	Max	0.5	0.5	0.5	0.5	mS
—	Thermal Offset Voltage 5mA control	Series or Parallel	Max	N/A	N/A	0.5	0.5	mV
C_O	Output Capacitance 5V _{DC}	Series or Parallel	Max	50	50	12	12	pF

Isolation Characteristics

Symbol	Characteristics	Test Conditions	Limit	HSR312	HSR312L	HSR412	HSR412L	Units
V_{ISO}	Input-Output Isolation Voltage	$I_{I-O} \leq 2 \mu\text{A}$	Max	4000	4000	4000	4000	V

Typical Performance Curves

Figure 1. Forward Current vs. Forward Voltage

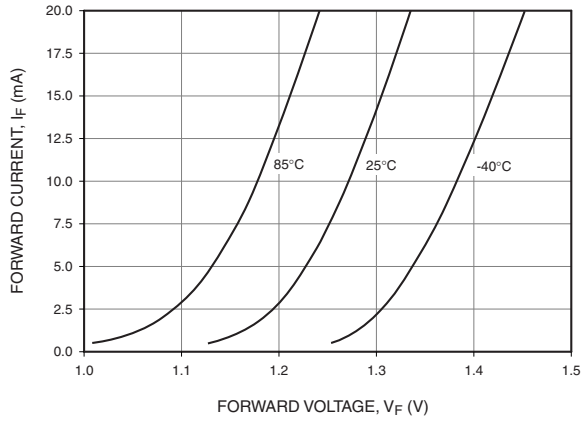

Figure 2. Normalized on Resistance vs. Ambient Temperature

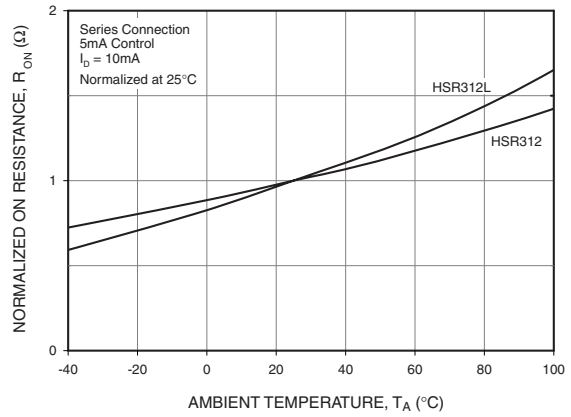

Figure 3. Normalized on Resistance vs. Ambient Temperature

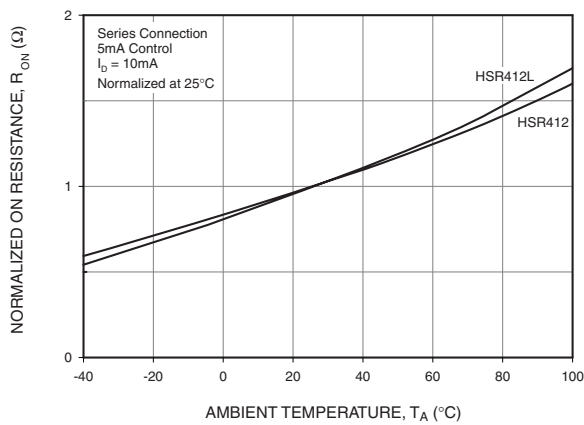

Figure 4. Load Current vs. Voltage Drop

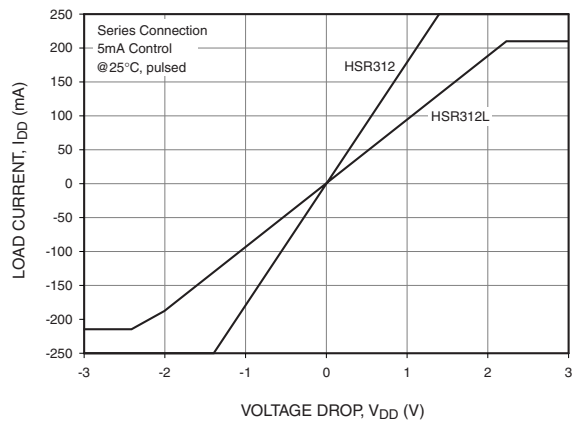

Figure 5. Load Current vs. Voltage Drop

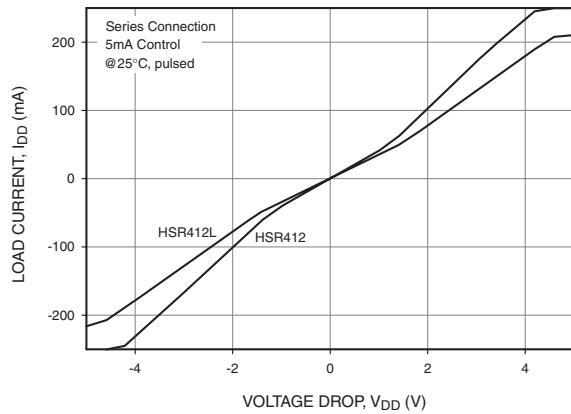

Figure 6. Maximum Load Current Vs Ambient Temperature

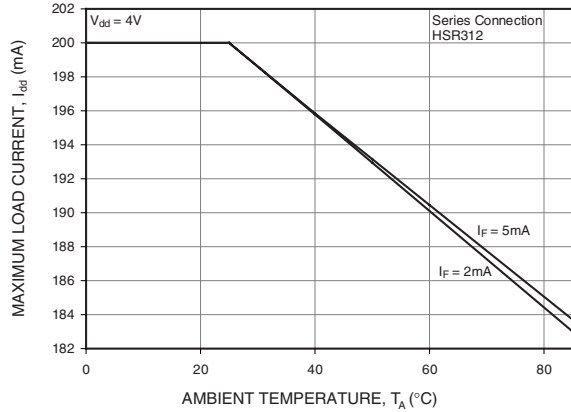

Figure 7. Maximum Load Current Vs Ambient Temperature

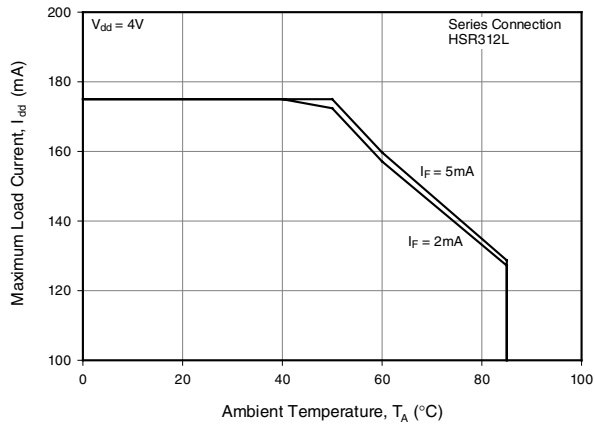

Figure 8. Maximum Load Current Vs Ambient Temperature

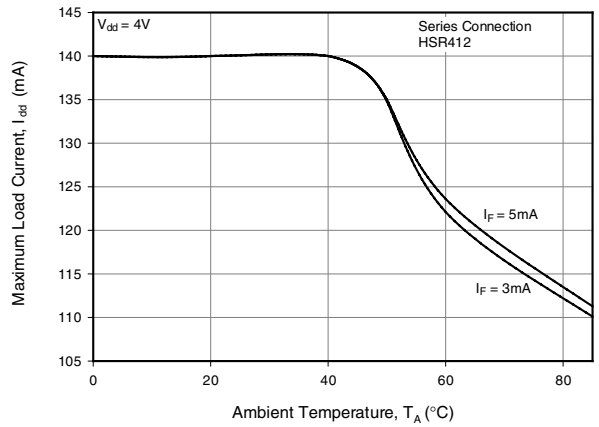

Figure 9. Maximum Load Current Vs Ambient Temperature

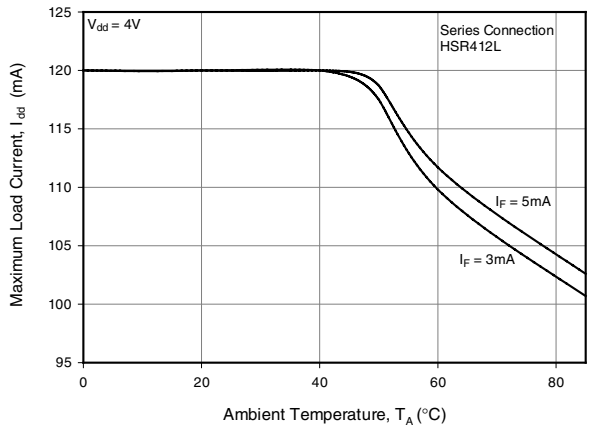

Figure 10. Off State Current vs. Ambient Temperature

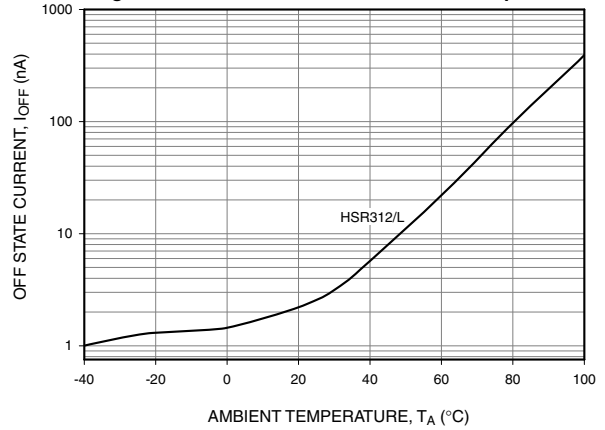

Figure 11. Off State Current vs. Ambient Temperature

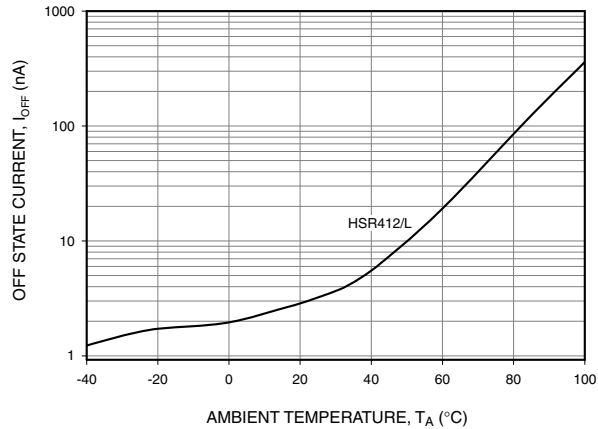

Figure 12. Normalized Off State Leakage vs. Ambient Temperature

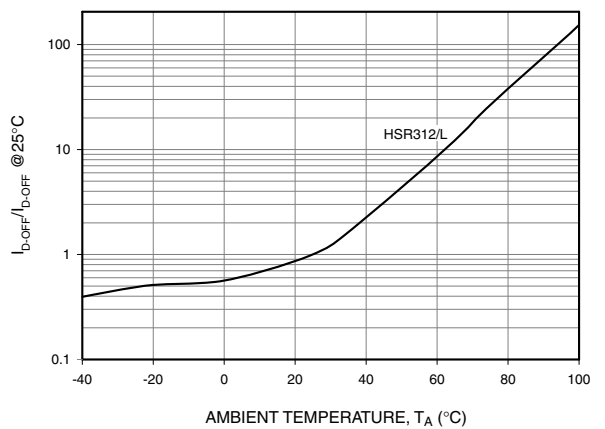
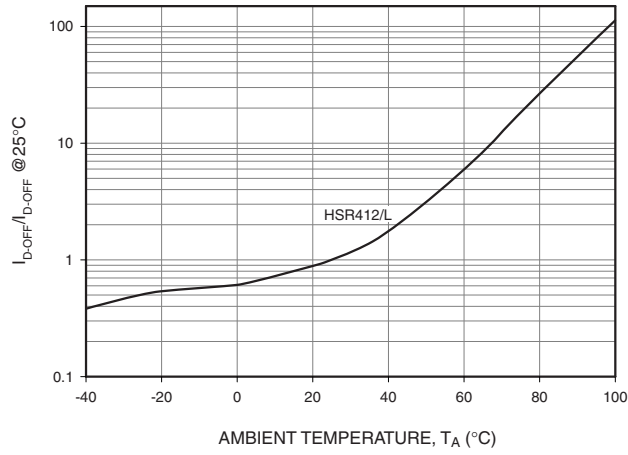
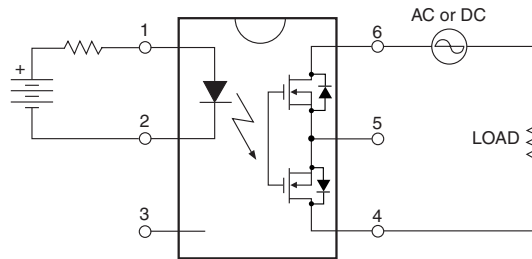

Figure 13. Normalized Off State Leakage vs. Ambient Temperature



Series Connection



Parallel Connection

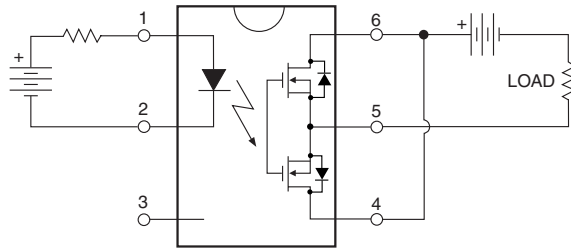

Package Dimensions

Through Hole

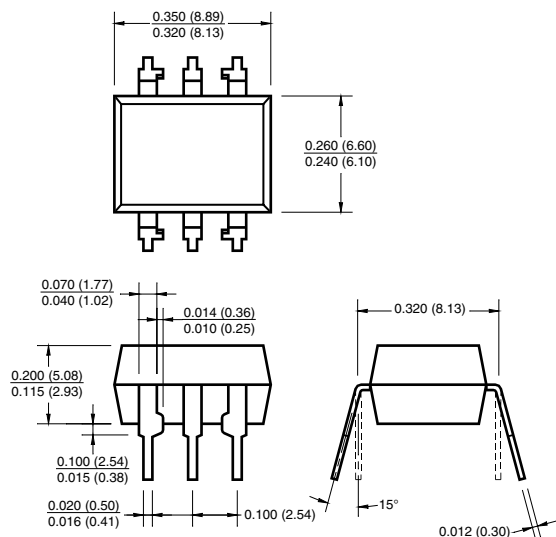

Surface Mount

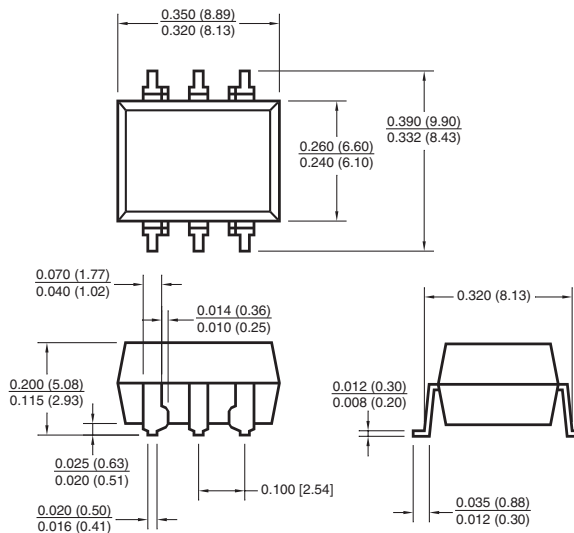

Recommended Pad Layout for Surface Mount Leadform

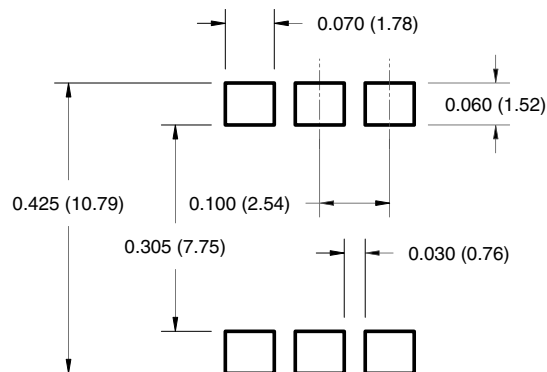

Note:

All dimensions are in inches (millimeters)

Ordering Information

Option	Part Number Example	Description
S	HSR312S	Surface Mount Lead Bend
SR2	HSR312SR2	Surface Mount; Tape and reel

Marking Information

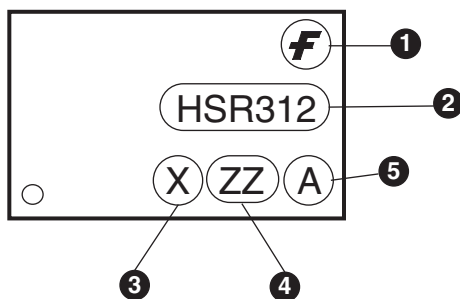

Definitions	
1	Fairchild logo
2	Device number
3	One digit year code
4	Two digit work week ranging from '01' to '53'
5	Assembly package code

Carrier Tape Specificatons (“D” Tapin Orientation)

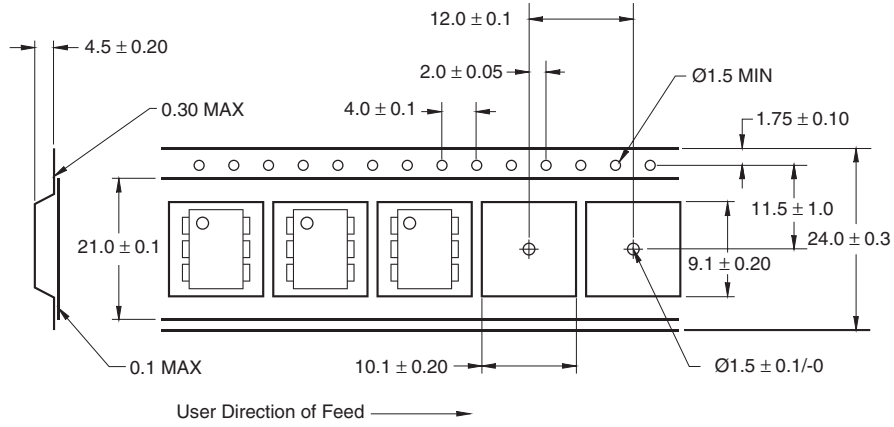

Note:

All dimensions are in inches (millimeters)

Reflow Profile

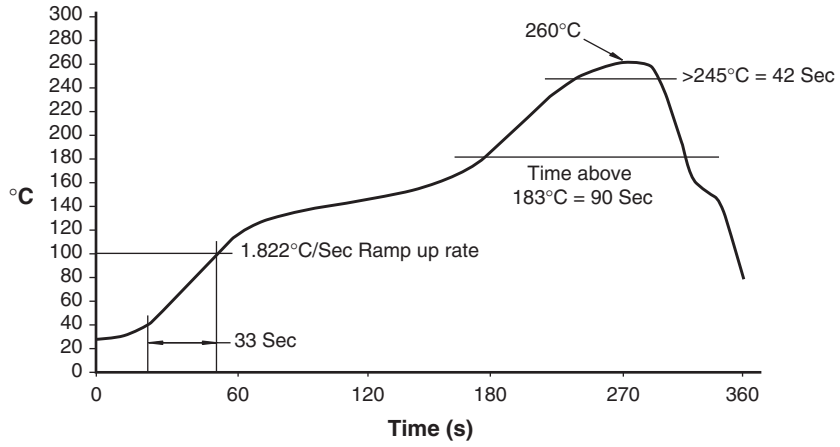

TRADEMARKS

The following are registered and unregistered trademarks Fairchild Semiconductor owns or is authorized to use and is not intended to be an exhaustive list of all such trademarks.

ACE [™]	FACT Quiet Series [™]	OCX [™]	SILENT SWITCHER [®]	UniFET [™]
ActiveArray [™]	GlobalOptoisolator [™]	OCXPro [™]	SMART START [™]	UltraFET [®]
Bottomless [™]	GTO [™]	OPTOLOGIC [®]	SPM [™]	VCX [™]
Build it Now [™]	HiSeC [™]	OPTOPLANAR [™]	Stealth [™]	Wire [™]
CoolFET [™]	I ² C [™]	PACMAN [™]	SuperFET [™]	
CROSSVOLT [™]	i-Lo [™]	POP [™]	SuperSOT [™] -3	
DOME [™]	ImpliedDisconnect [™]	Power247 [™]	SuperSOT [™] -6	
EcoSPARK [™]	IntelliMAX [™]	PowerEdge [™]	SuperSOT [™] -8	
E ² CMOS [™]	ISOPLANAR [™]	PowerSaver [™]	SyncFET [™]	
EnSigna [™]	LittleFET [™]	PowerTrench [®]	TCM [™]	
FACT [™]	MICROCOUPLER [™]	QFET [®]	TinyBoost [™]	
FAST [®]	MicroFET [™]	QS [™]	TinyBuck [™]	
FASTr [™]	MicroPak [™]	QT Optoelectronics [™]	TinyPWM [™]	
FPS [™]	MICROWIRE [™]	Quiet Series [™]	TinyPower [™]	
FRFET [™]	MSX [™]	RapidConfigure [™]	TinyLogic [®]	
	MSXPro [™]	RapidConnect [™]	TINYOPTO [™]	
Across the board. Around the world. [™]		μSerDes [™]	TruTranslation [™]	
The Power Franchise [®]		ScalarPump [™]	UHC [™]	
Programmable Active Droop [™]				

DISCLAIMER

FAIRCHILD SEMICONDUCTOR RESERVES THE RIGHT TO MAKE CHANGES WITHOUT FURTHER NOTICE TO ANY PRODUCTS HEREIN TO IMPROVE RELIABILITY, FUNCTION, OR DESIGN. FAIRCHILD DOES NOT ASSUME ANY LIABILITY ARISING OUT OF THE APPLICATION OR USE OF ANY PRODUCT OR CIRCUIT DESCRIBED HEREIN; NEITHER DOES IT CONVEY ANY LICENSE UNDER ITS PATENT RIGHTS, NOR THE RIGHTS OF OTHERS. THESE SPECIFICATIONS DO NOT EXPAND THE TERMS OF FAIRCHILD'S WORLDWIDE TERMS AND CONDITIONS, SPECIFICALLY THE WARRANTY THEREIN, WHICH COVERS THESE PRODUCTS.

LIFE SUPPORT POLICY

FAIRCHILD'S PRODUCTS ARE NOT AUTHORIZED FOR USE AS CRITICAL COMPONENTS IN LIFE SUPPORT DEVICES OR SYSTEMS WITHOUT THE EXPRESS WRITTEN APPROVAL OF FAIRCHILD SEMICONDUCTOR CORPORATION.

As used herein:

- Life support devices or systems are devices or systems which, (a) are intended for surgical implant into the body, or (b) support or sustain life, or (c) whose failure to perform when properly used in accordance with instructions for use provided in the labeling, can be reasonably expected to result in significant injury to the user.
- A critical component is any component of a life support device or system whose failure to perform can be reasonably expected to cause the failure of the life support device or system, or to affect its safety or effectiveness.

PRODUCT STATUS DEFINITIONS

Definition of Terms

Datasheet Identification	Product Status	Definition
Advance Information	Formative or In Design	This datasheet contains the design specifications for product development. Specifications may change in any manner without notice.
Preliminary	First Production	This datasheet contains preliminary data, and supplementary data will be published at a later date. Fairchild Semiconductor reserves the right to make changes at any time without notice to improve design.
No Identification Needed	Full Production	This datasheet contains final specifications. Fairchild Semiconductor reserves the right to make changes at any time without notice to improve design.
Obsolete	Not In Production	This datasheet contains specifications on a product that has been discontinued by Fairchild semiconductor. The datasheet is printed for reference information only.

Rev. I20